

### Contents

#### Portable Banner Display Frames

- Features
- Standard Duty
- Double sided
- Heavy Duty
- Factors You Need to know
- Elevated
- Bungees
- Overhead
- Spiked Base

#### Semi - Permanent Banner Frames

- Features
- Maxi Frame fittings
- Tube Sizes

### Banner Display Frame Specifications

#### Portable and Permanent

The JMS range of banner frames offers a high-quality solution for any location or event – and because we manufacture, requests for unusual or non-standard types of frames are welcome.

We do our best to provide a first-class answer.

#### Portable Banner Frames Permanent Banner Frames

#### Factors we need to know

- Standard duty?
- Heavy duty?
- Single sided?
- Double sided?
- Softstanding?
- Hardstanding?
- Temporary bases?
- Permanent installations?

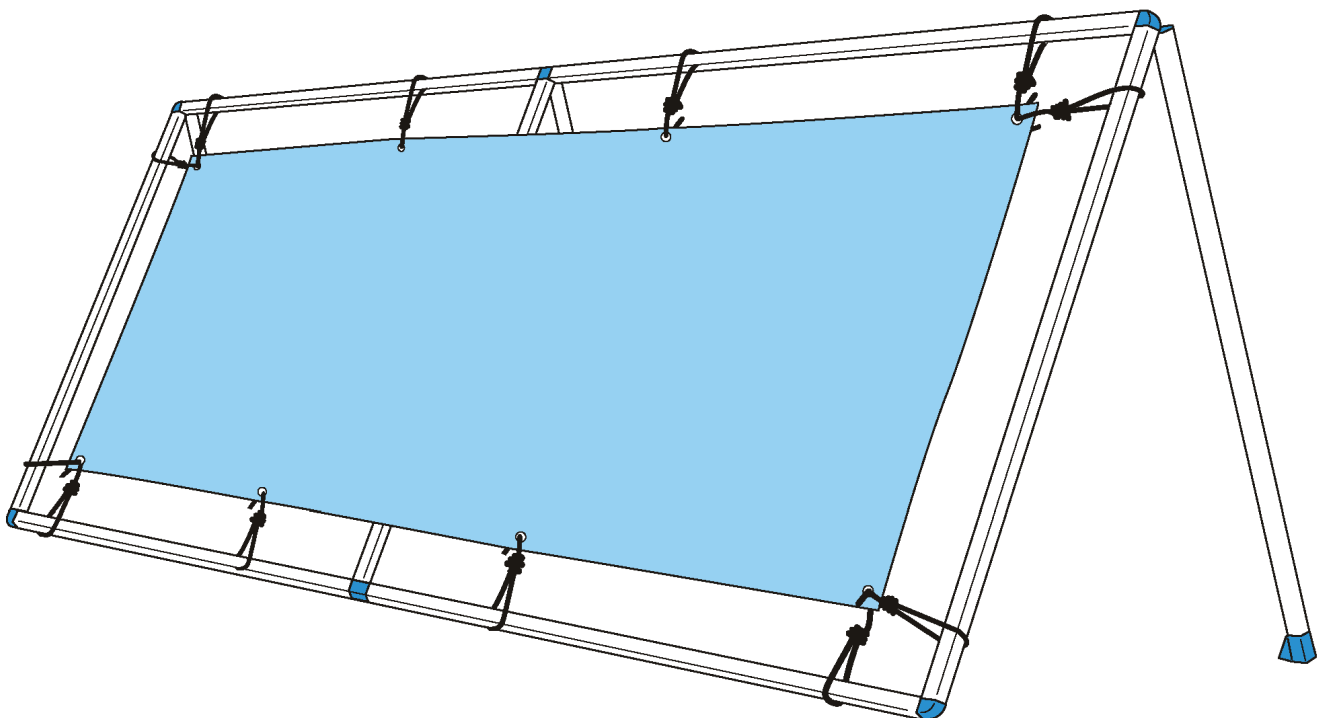

### Banner Display Frame Specifications

#### Standard Duty Frames

Our Standard Frame is typically used on golf courses, at sporting events and exhibitions.

Made from 25mm square anodised aluminium tube with plastic push-fit joints, our Standard Duty Banner Frames are suitable for outdoor or indoor use. Each frame comes with looped elastics to secure and tension the banner, carrying bag, and a set of pegs for outdoor events. The modular structure gives sufficient flexibility for different banner sizes, whilst even the longest element fits easily into a standard car.

(We can adapt for smaller cars too)

#### For outdoor use and can be adapted for indoors

- Made from anodised aluminium square tube
- Push fit plastic joints – no screws necessary
- Support legs are hinged to frame uprights
- Frame can be anchored to the ground with pegs
- Frame becomes tensioned when the banner is in place
- Pegs and looped elastics are provided together with carrying bag for ease of storage and transport
- Maximum tube length is 6ft (1.8m), so frame easily fits into the back of a car
- Frames basically made up of 5 x 3ft (1.52 x 0.914m) modules. This is flexible to suit different banner sizes
- Maximum recommended banner size 30 x 3ft (9.144 x 0.914m)
- Struts can be added to the legs to enable frames to be used on hard standing or indoors

#### Factors you need to know

- Double-sided to display the banners on the same frame.
- 6" or 3" gap all around the banner

### Banner Display Frame Specifications

#### Standard Duty Frames

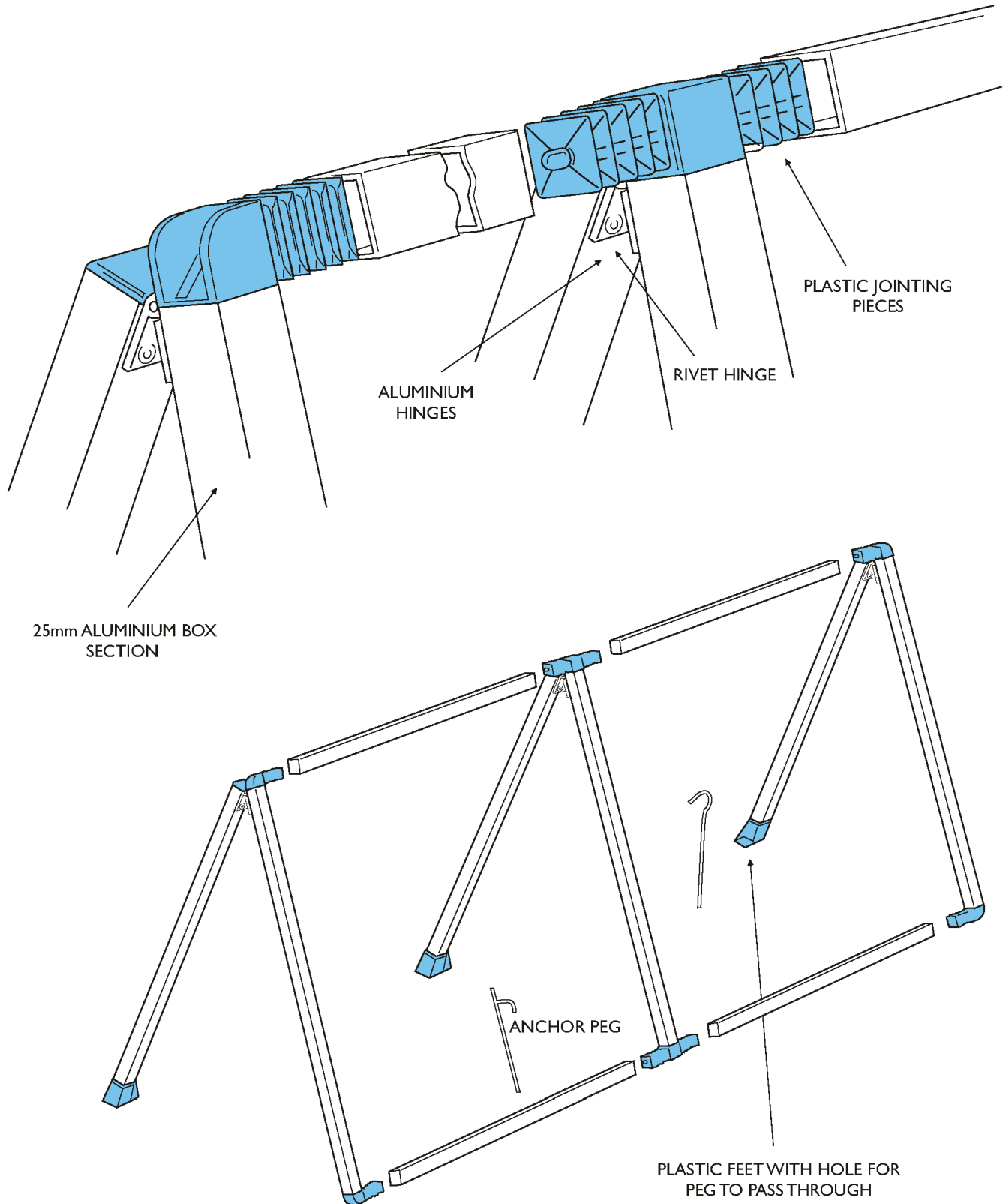

### Banner Display Frame Specifications

#### Double Sided Frames

Our Standard Banner Frames can also be supplied in Double Frame format, allowing banners to be attached to either side when all-round visibility is needed. Struts are added for extra support.

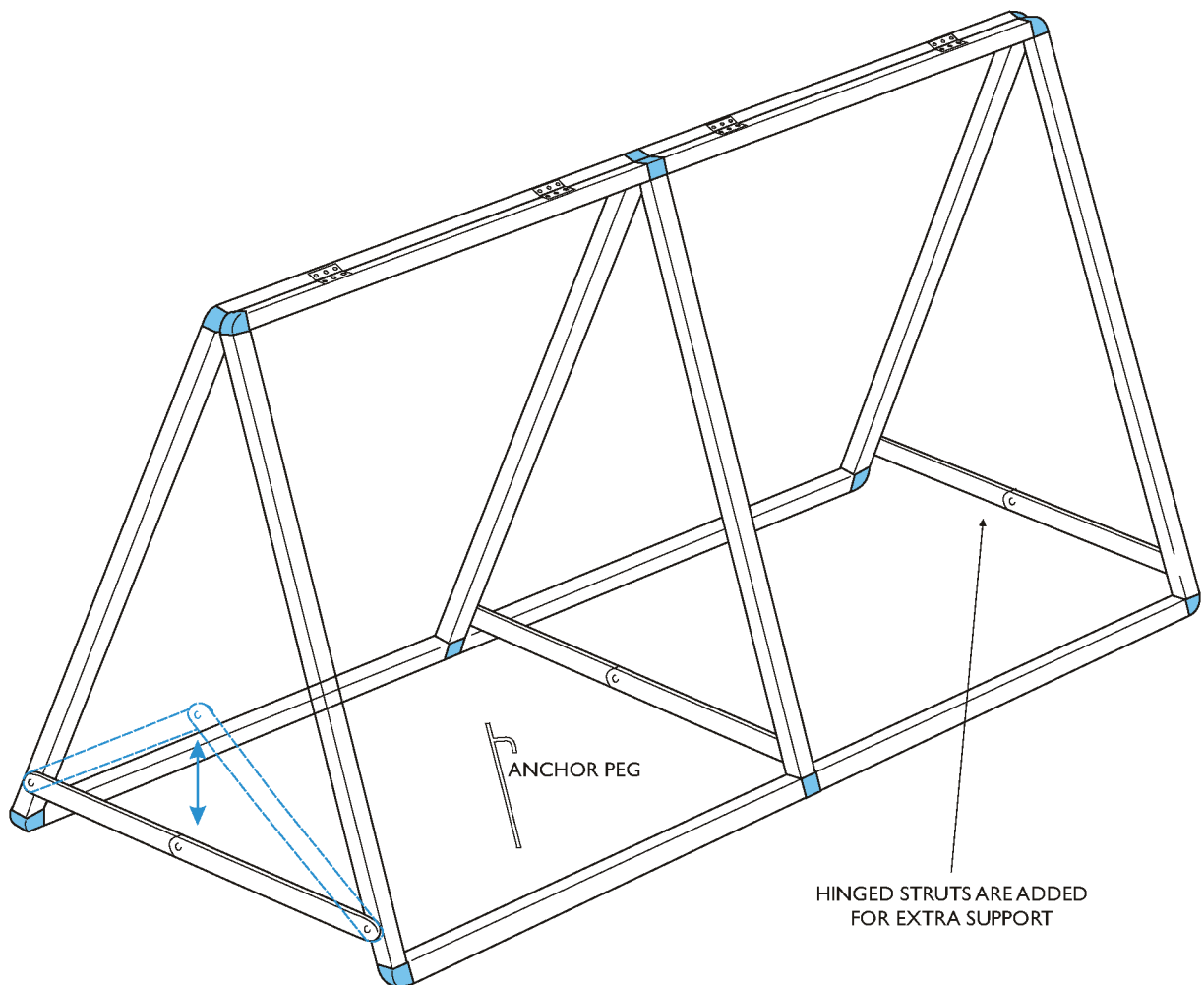

| Double-sided Banner Frames |            |
|----------------------------|------------|
| TO ACCEPT BANNER SIZE (mm) |            |
|                            | 1500 × 915 |
|                            | 3050 × 915 |
|                            | 4570 × 915 |
|                            | 6100 × 915 |
|                            | 7620 × 915 |
|                            | 9144 × 915 |

### Banner Display Frame Specifications

#### Heavy Duty Frames

#### Factors you need to know

- Made from anodised aluminum 30mm diameter tube
- Cast aluminium joints for strength with rubber 'O' rings for ease of fitting
- Frame can be anchored with pegs
- Frame becomes tensioned when banner is in place
- Pegs and looped elastic are provided together with carrying bag for ease of storage and transport
- Fits easily into the back of a car
- Frames basically made up of 5ft x 3ft (1.524m x 0.914m) modules. This is flexible to suit different banner sizes
- Maximum recommended banner size 20ft x 4ft (6.10m x 1.2m) or 30ft x 3ft (9.144m x 0.914m)
- 6" or 3" gap all round banner
- NOT suitable for hard-standing

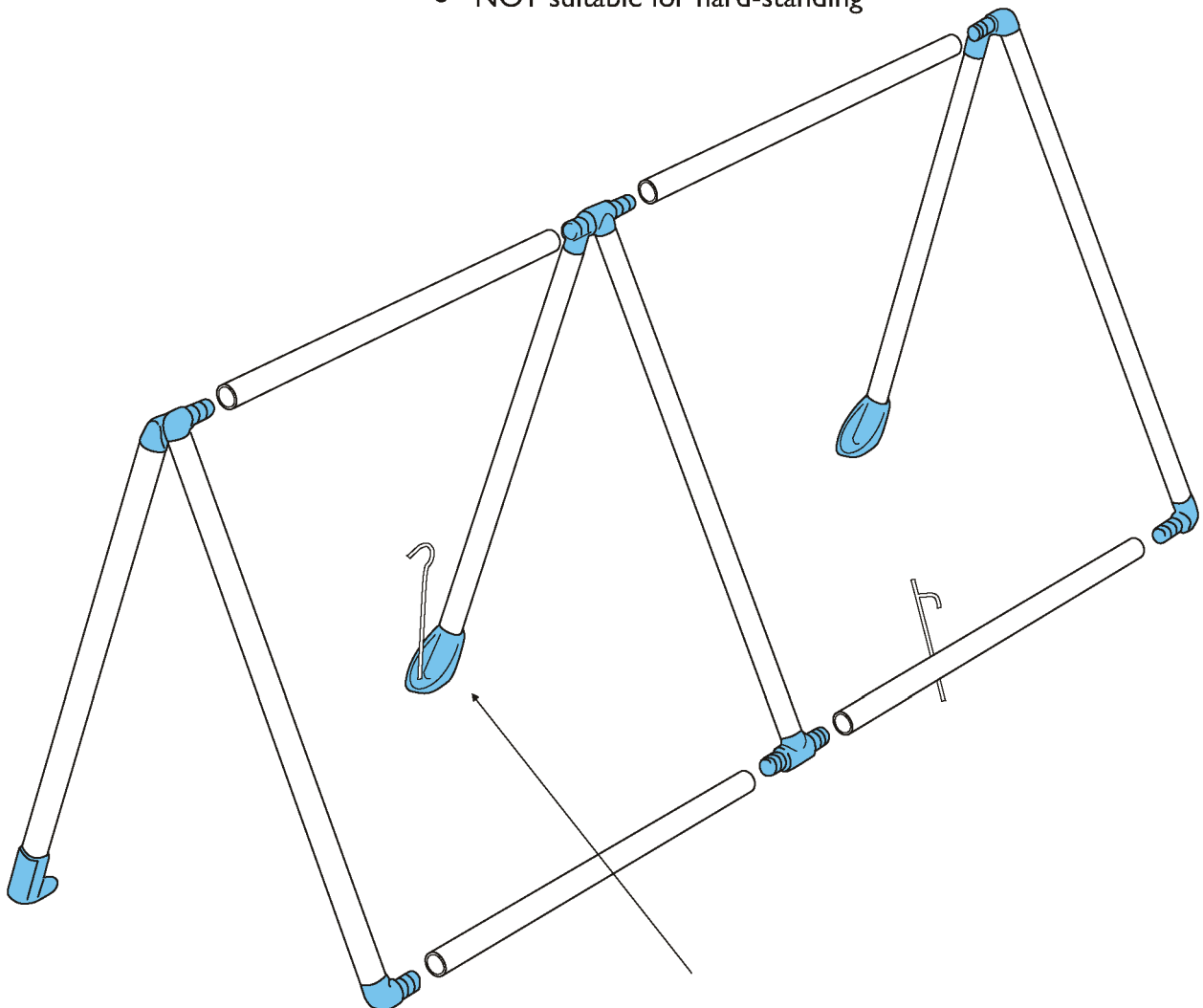

ROUND PLASTIC FEET FOR  
THE PEG TO PASS THROUGH

### Banner Display Frame Specifications

#### Heavy Duty Frames

For frequent outdoor use, built to stand the rigors of an outdoor exhibition season.

NOT suitable for hard-standing.

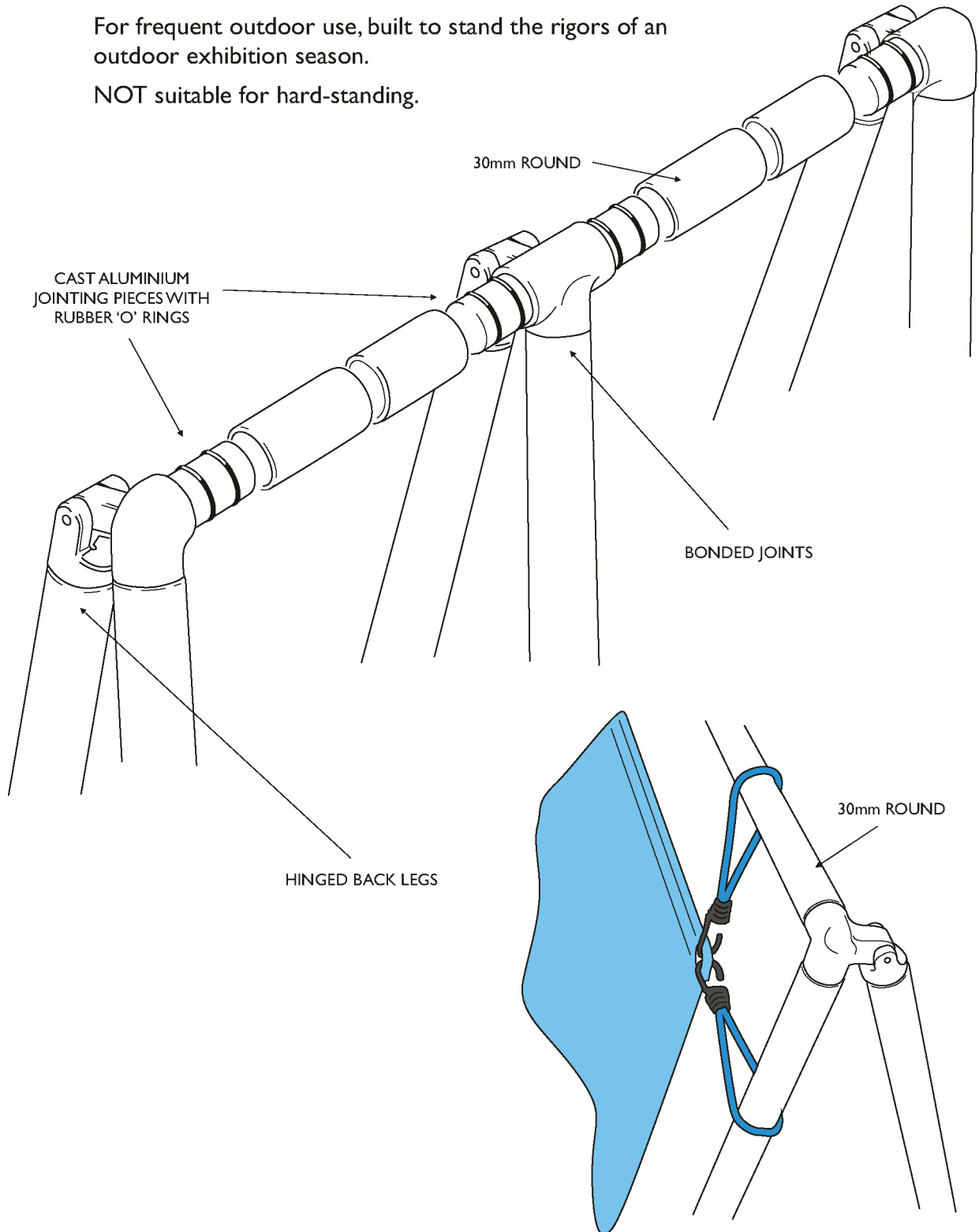

### Banner Display Frame Specifications

#### Elevated Banner Frame

Take control of your audience! Portability is really about having the ability to install branding or advertising in the most favourable position, giving maximum impact whatever the location.

Don't compromise on 'out of the way' or obscured positions. Think about visitor flow and camera positions.

Remember to tell our sales advisor whether you will be using your banner frames on hard or soft standing.

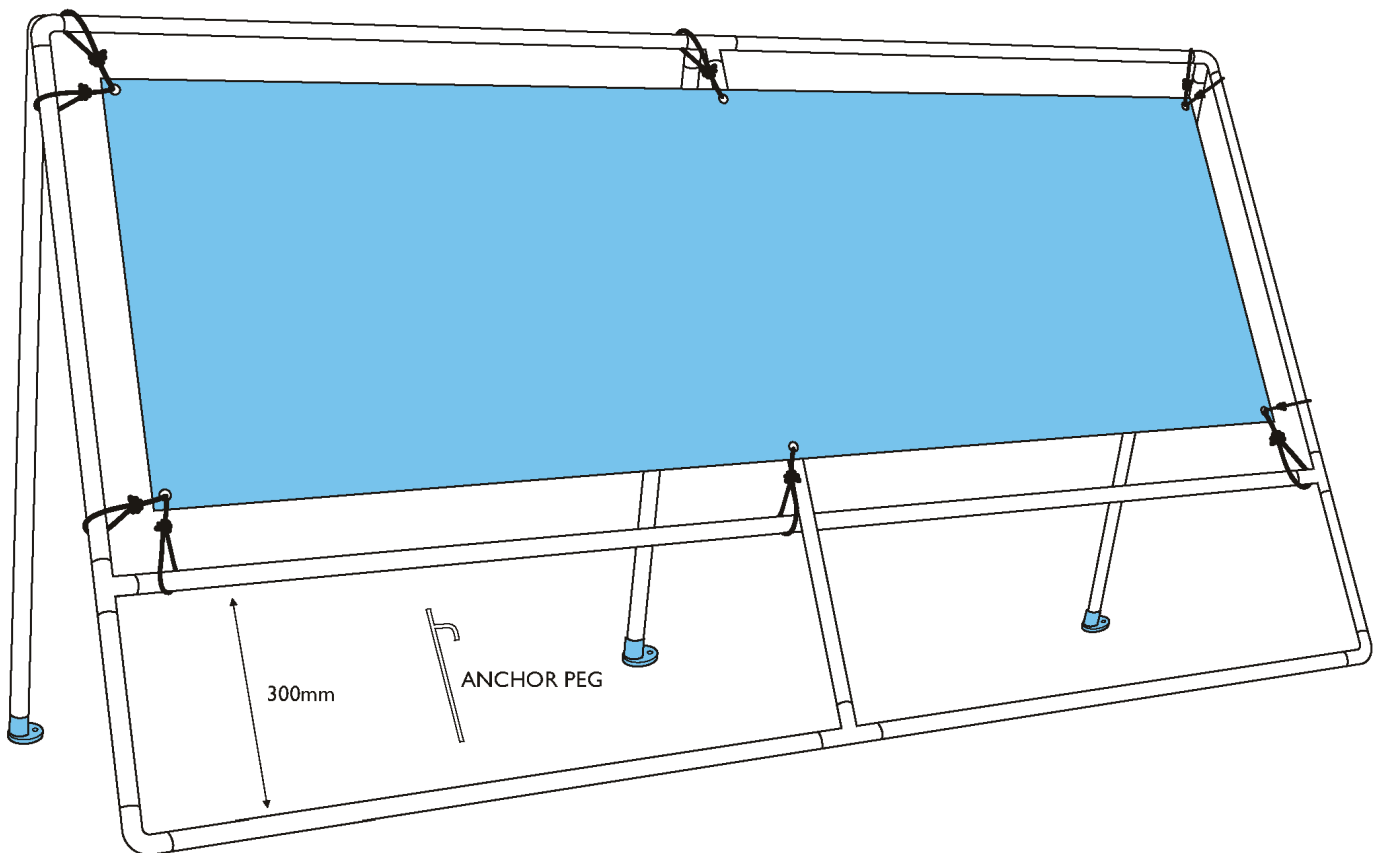

### Banner Display Frame Specifications

#### Banner Ties

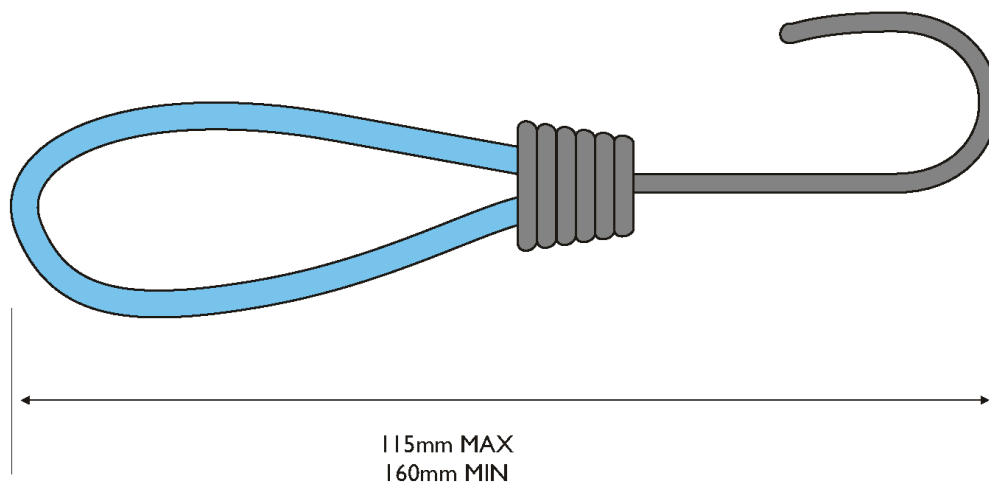
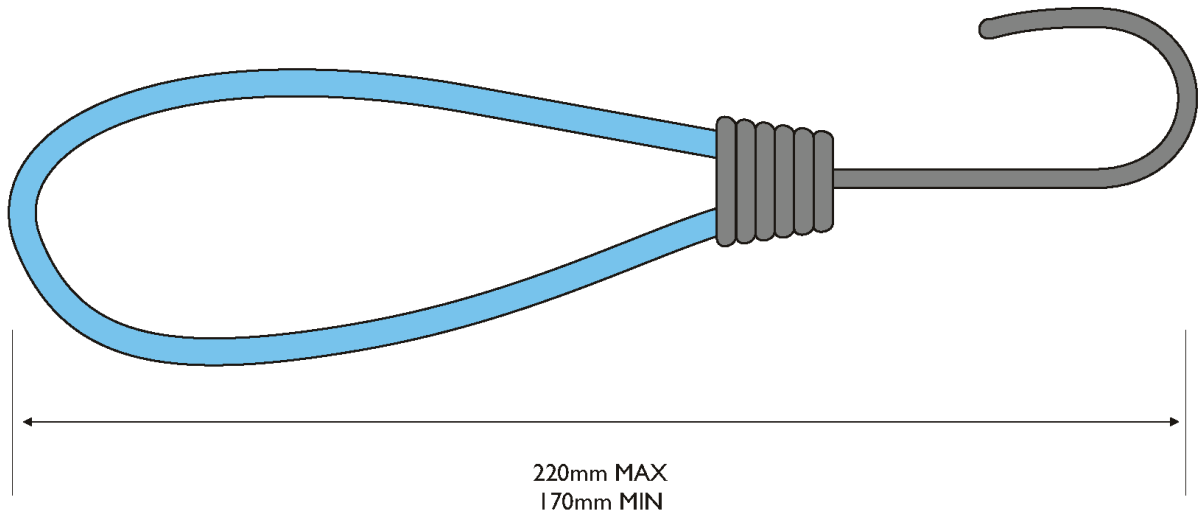

### Banner Display Frame Specifications

#### Overhead Banner Frame

##### Maximum banner height is 3ft

If you need your message to stand head and shoulders above the rest, the Overhead Banner Frame is an ideal solution.

Manufactured from 44.5mm diameter anodised aluminium tube with machined aluminium joints, this sturdy frame is anchored to the ground with base spikes, guy ropes and heavy duty pegs.

The Overhead Banner Frame can be supplied in Single Span (banners up to 12ft x 3ft) or Double Span (banners up to 22ft x 3ft).

To ensure your prominently-positioned banner looks its best throughout the event, the banner is sleeved on to the cross bar of the Overhead Frame.

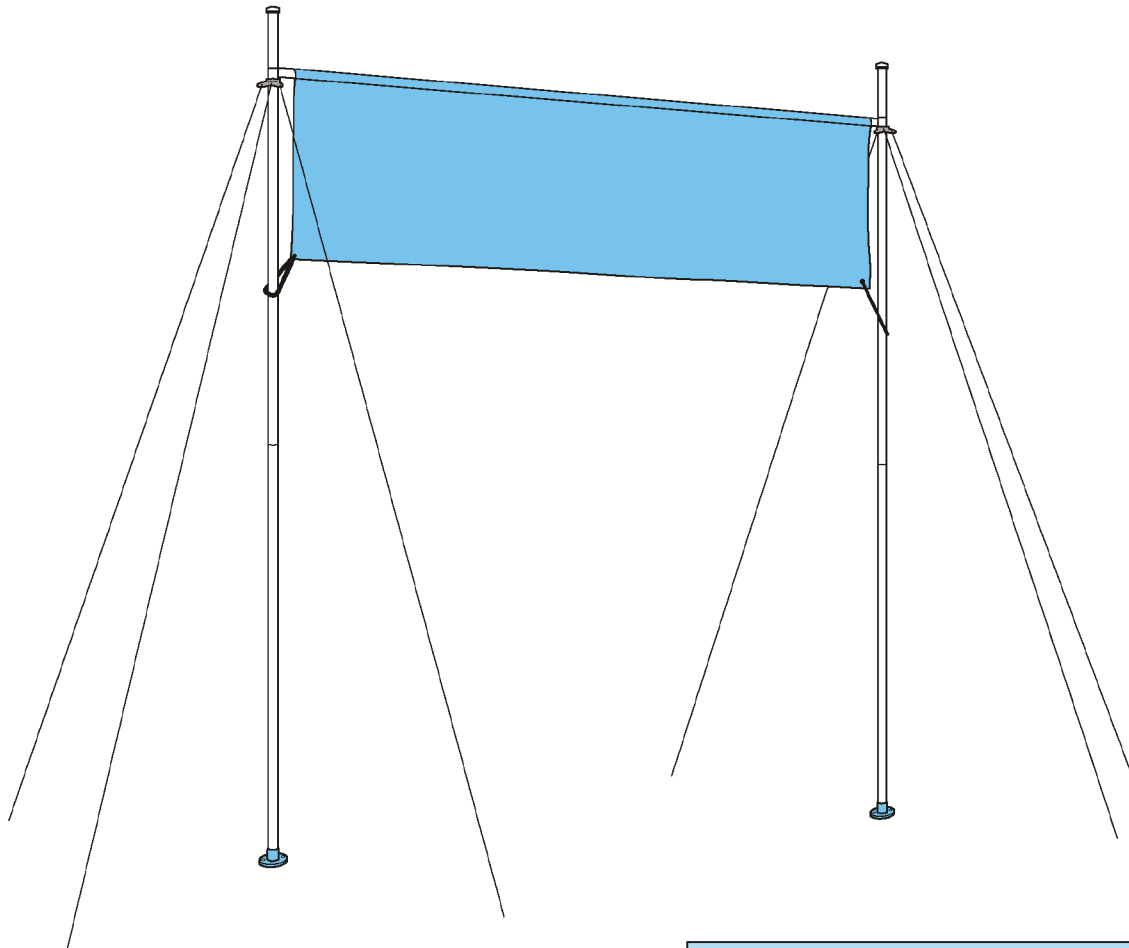

#### Heavy duty overhead frames

##### DESCRIPTION

|              |        |
|--------------|--------|
| Single span  | 3660mm |
| Banner width | 3600mm |
| Double span  | 6710mm |

### Banner Display Frame Specifications

#### Overhead Banner Frame

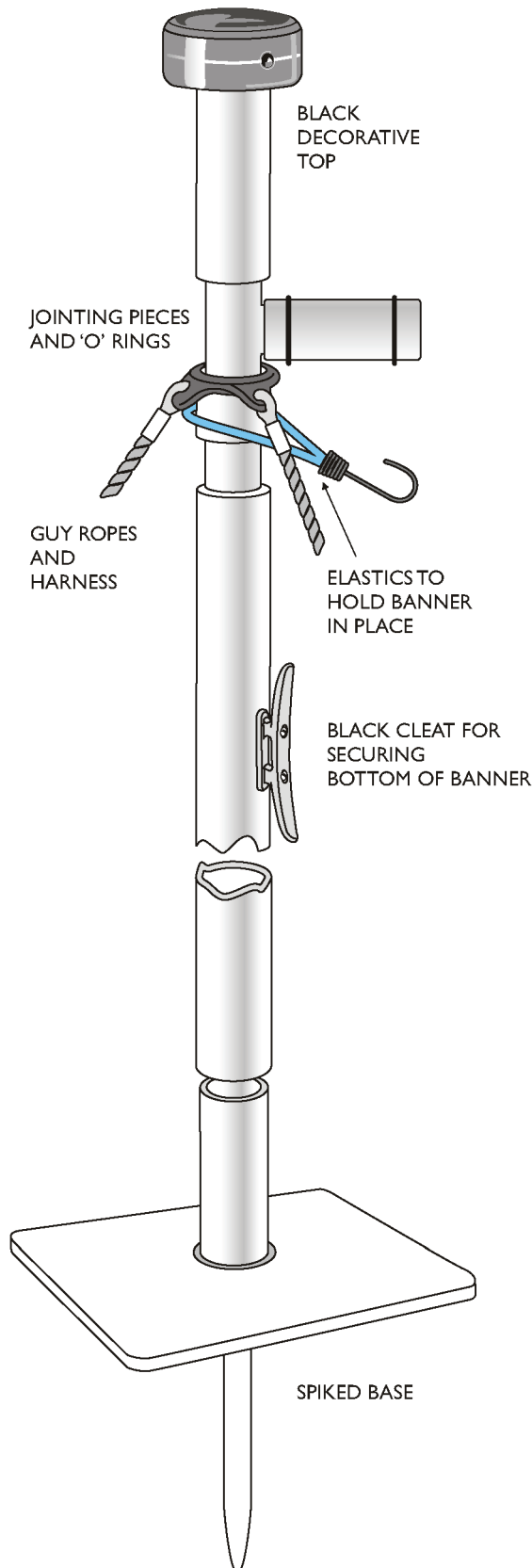

#### Stand out above the rest

Made from anodised aluminium 44.5mm diameter tube. Machined aluminium joints fitted with rubber 'O' rings for strength and easy fit.

Frame anchored to the ground with spiked bases, guy ropes and heavy duty pegs. All fittings are included together with carrying bags for ease of storage and transport.

Fits easily into the back of a car.

Frame can be 'single' and display a banner up to 12ft x 3ft (3657mm x 914mm), or 'double' and display a banner of up to 22ft x 3ft 6.706m x 0.914m

Banner is sleeved onto the cross bar to maintain its shape and line.

### Banner Display Frame Specifications

#### Overhead Banner Frame

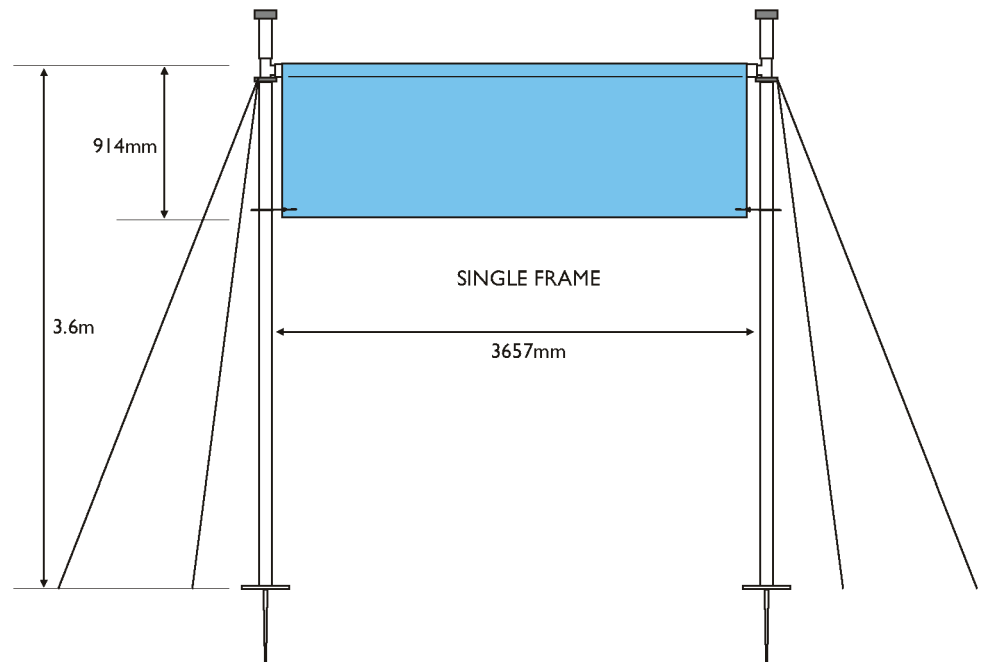
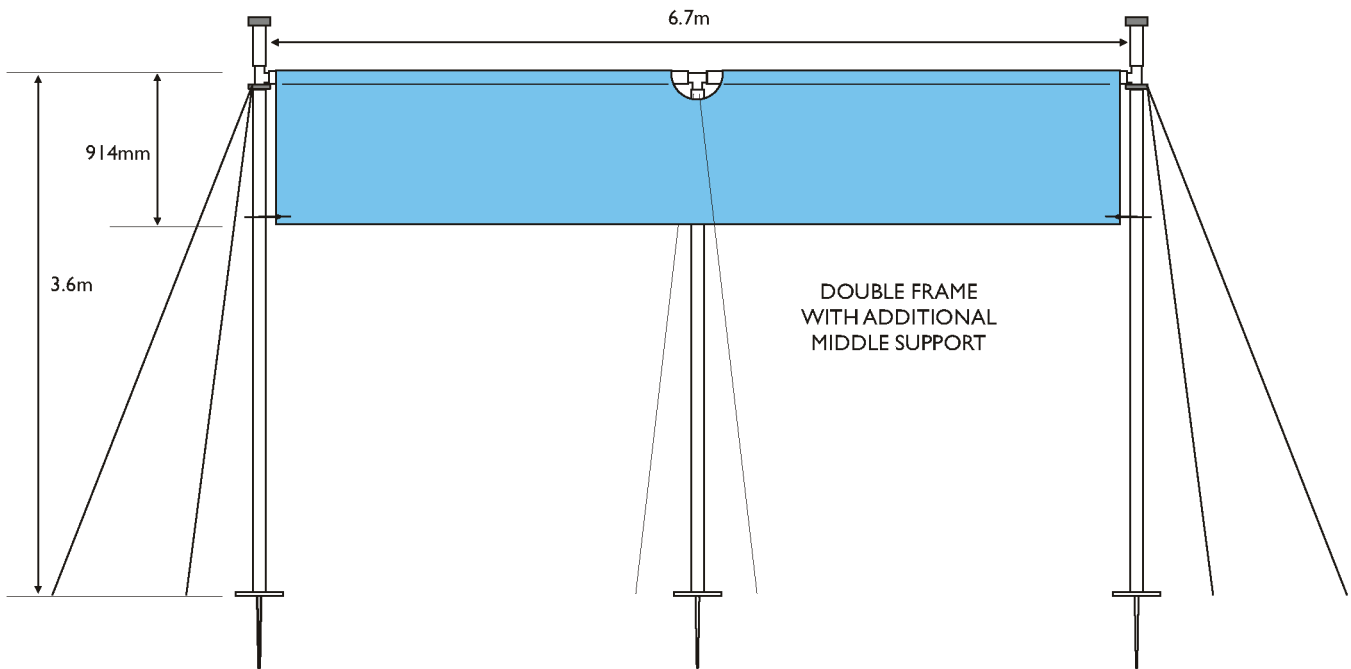

### Banner Display Frame Specifications

#### Soft Earth Spikes

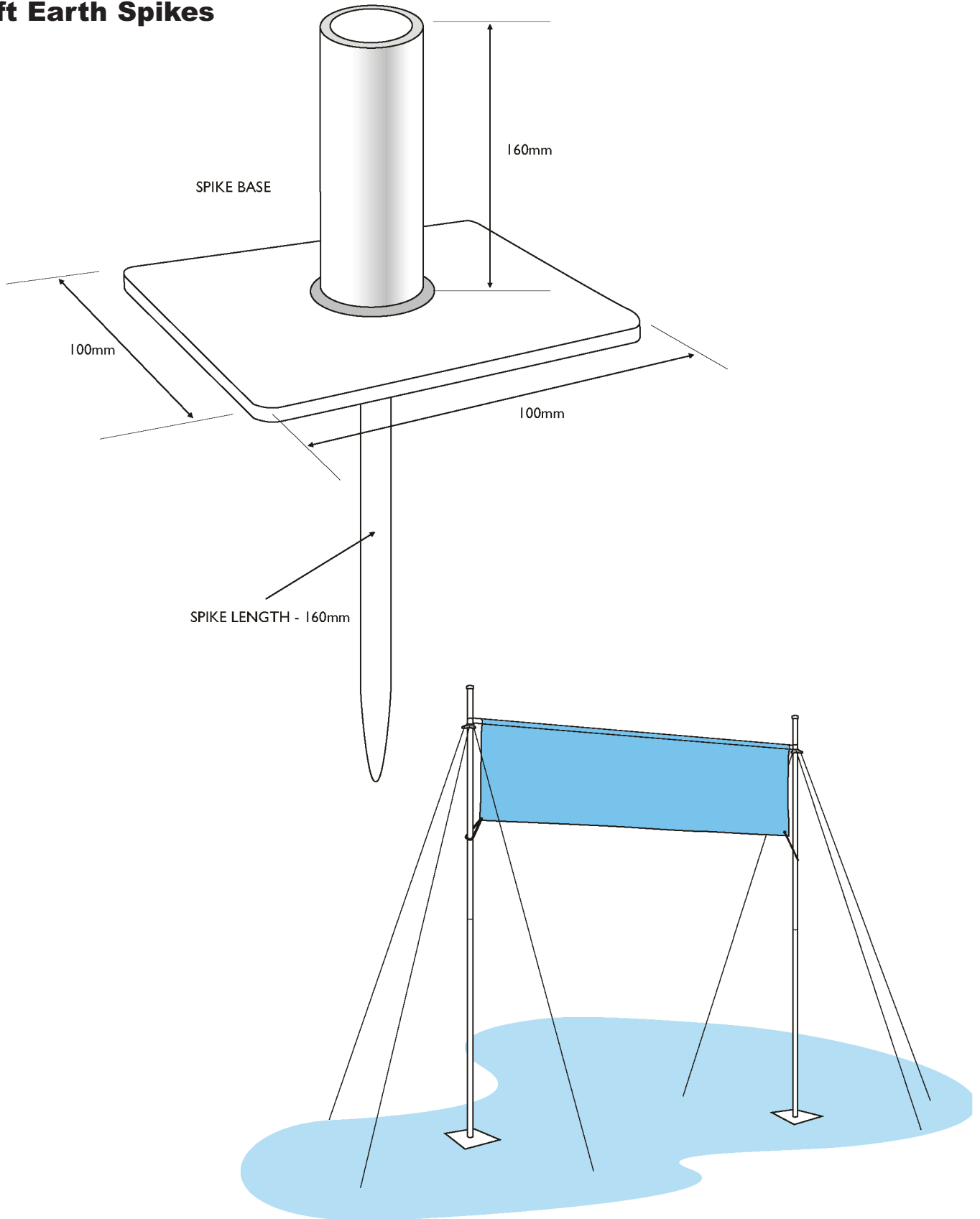

## Banner Display Frame Specifications

### The Maxi Frame

#### For long term use in demanding road-side locations

These galvanised steel banner frames offer extreme heavy duty performance whilst still allowing you to occasionally change the positioning of the frame or the message of the banner.

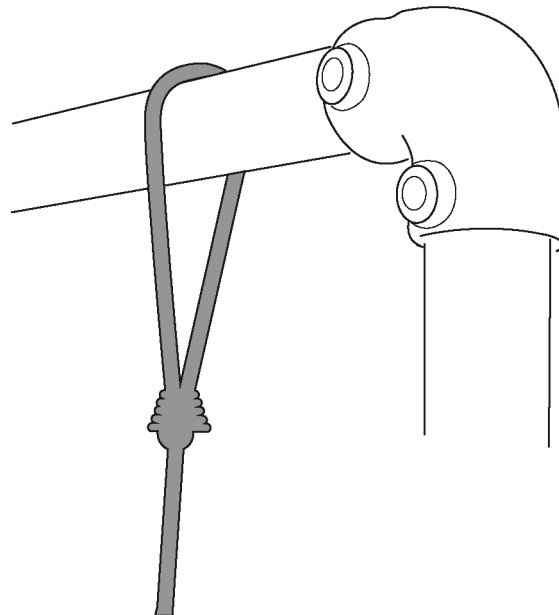
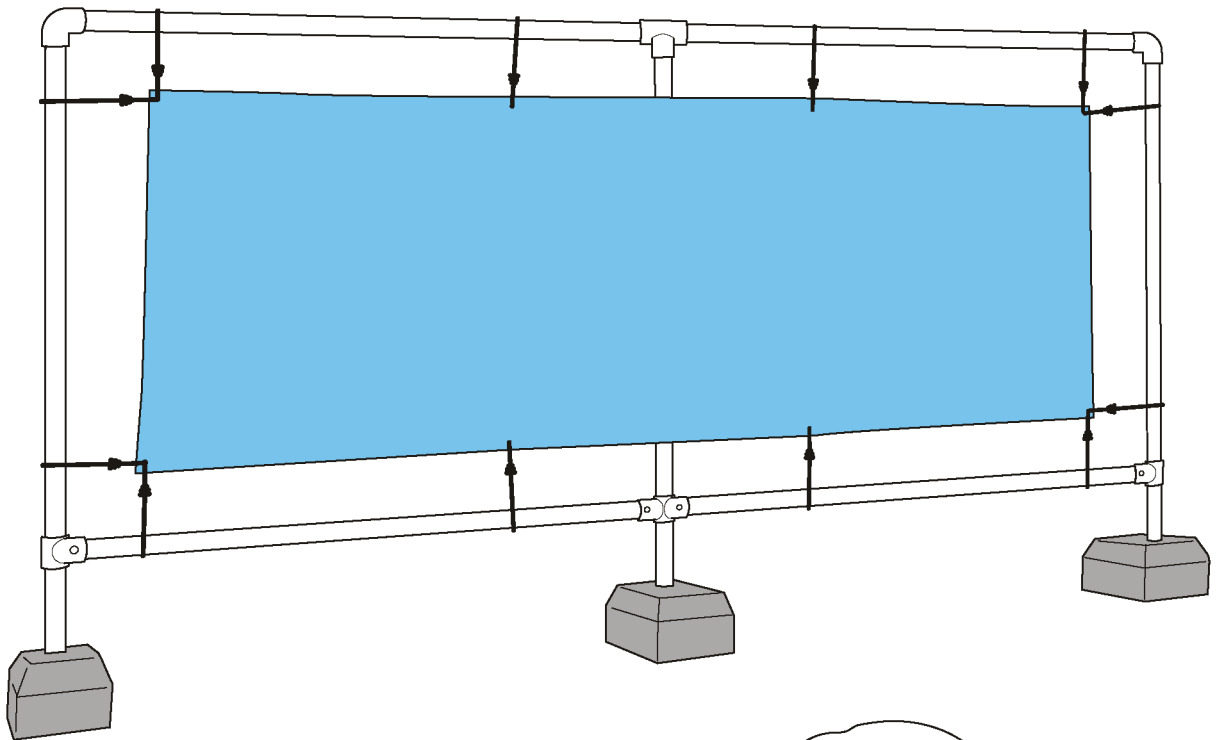

### Banner Display Frame Specifications

#### The Maxi Frame

MaxiFrame from JMS Flagpoles offers the ultimate in heavy duty frames without needing to create fixed signage. The MaxiFrame is built from sturdy steel sections, so you can be sure that whatever the British weather can throw at it, your banner will still be professionally displayed, day after day. The MaxiFrame is available with three different base options.

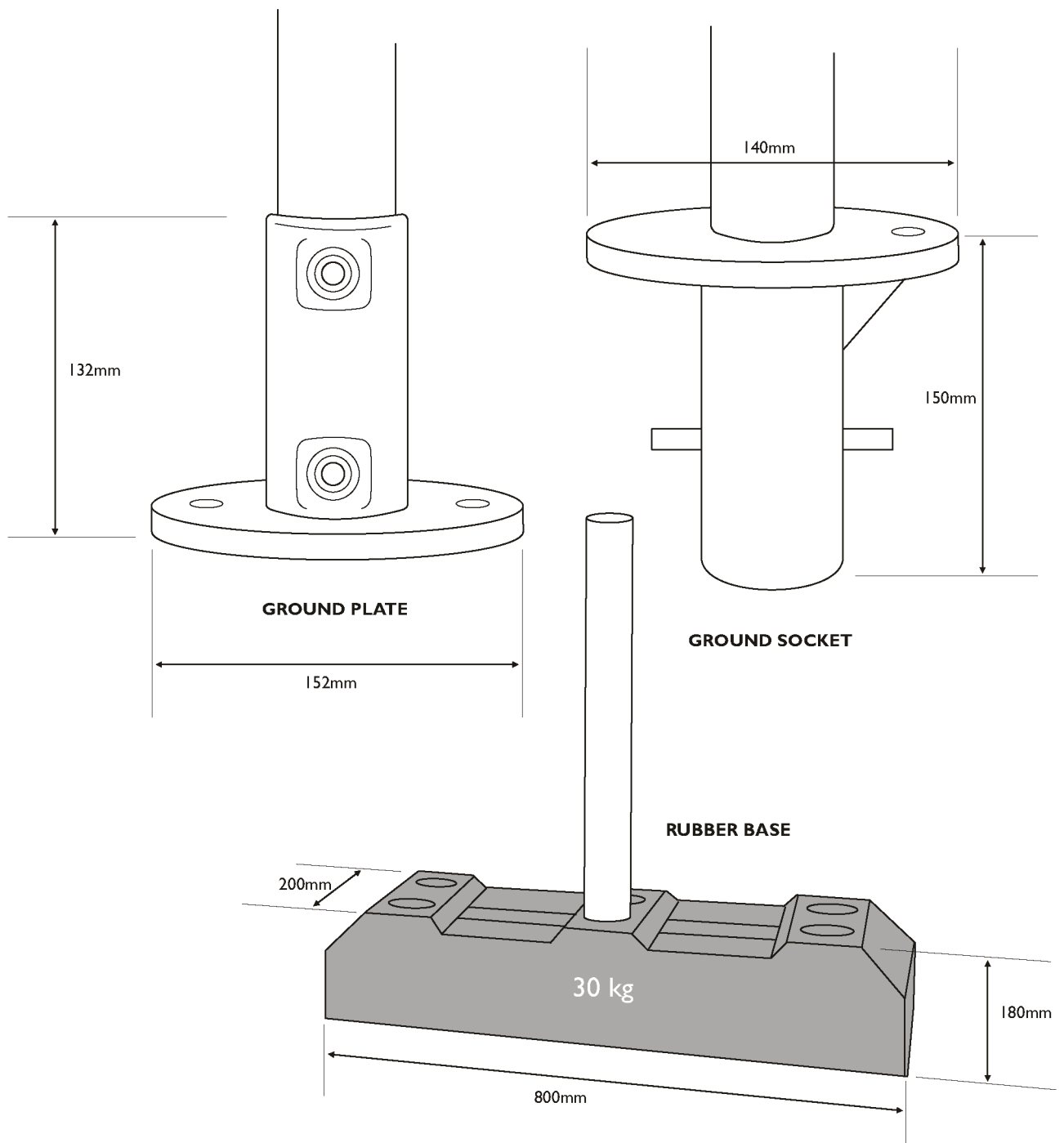

## Banner Display Frame Specifications

### The Maxi Frame

#### Joints and angles

Tube size 40mm

